

5. SECOND STAGE AIR CYLINDER ASSEMBLY (For HX2T-50NP/D & HX2T-60NP/D)

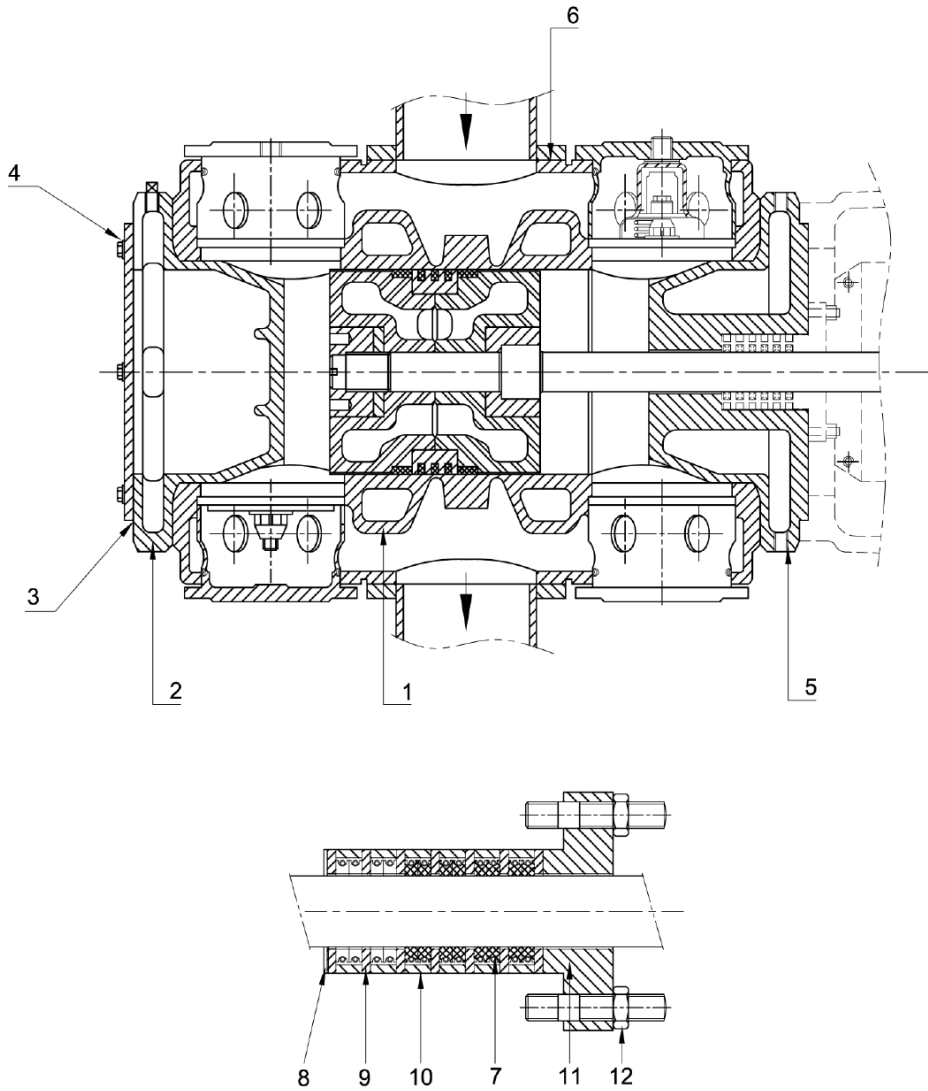

5. SECOND STAGE AIR CYLINDER ASSEMBLY
(For HX2T-50NP/D & HX2T-60NP/D)

No.	Description	Ref Part No.	QTY
1	Cylinder Assembly (Dia. 160)	1903909195	1
-	Door (Pressed)	1901003348	2
-	Gasket for Door	1903073012	2
-	Cu. washer	1903361913	20
2	Cylinder Head Assembly (Outer)	1903903895	1
-	Gasket	1903079108	2
3	*Gasket for Closing Plate	1901003831	1
4	*Closing Plate	1901006265	1
5	Cylinder Head Assembly (Inner)	1903903795	1
-	Gasket for water passage	1901003804	1
6	Gasket for Cylinder Inlet and Outlet Flange	1903074508	2
-	Packing Ring Set (First stage)	1903007095	1
7	*Packing Ring	1903145508	12
8	Aluminium Washer	1903074108	1
9	Intermediate Ring	1901006279	7
10	Sleeve	1903963804	1
11	Packing Flange	-	1
12	Hellilock Nut	1903206213	4